

Ersatzteile für
Brenner-Typen WL20

Spare parts
for burner types WL20

Pièces de rechange
pour brûleurs type
WL20

-weishaupt-

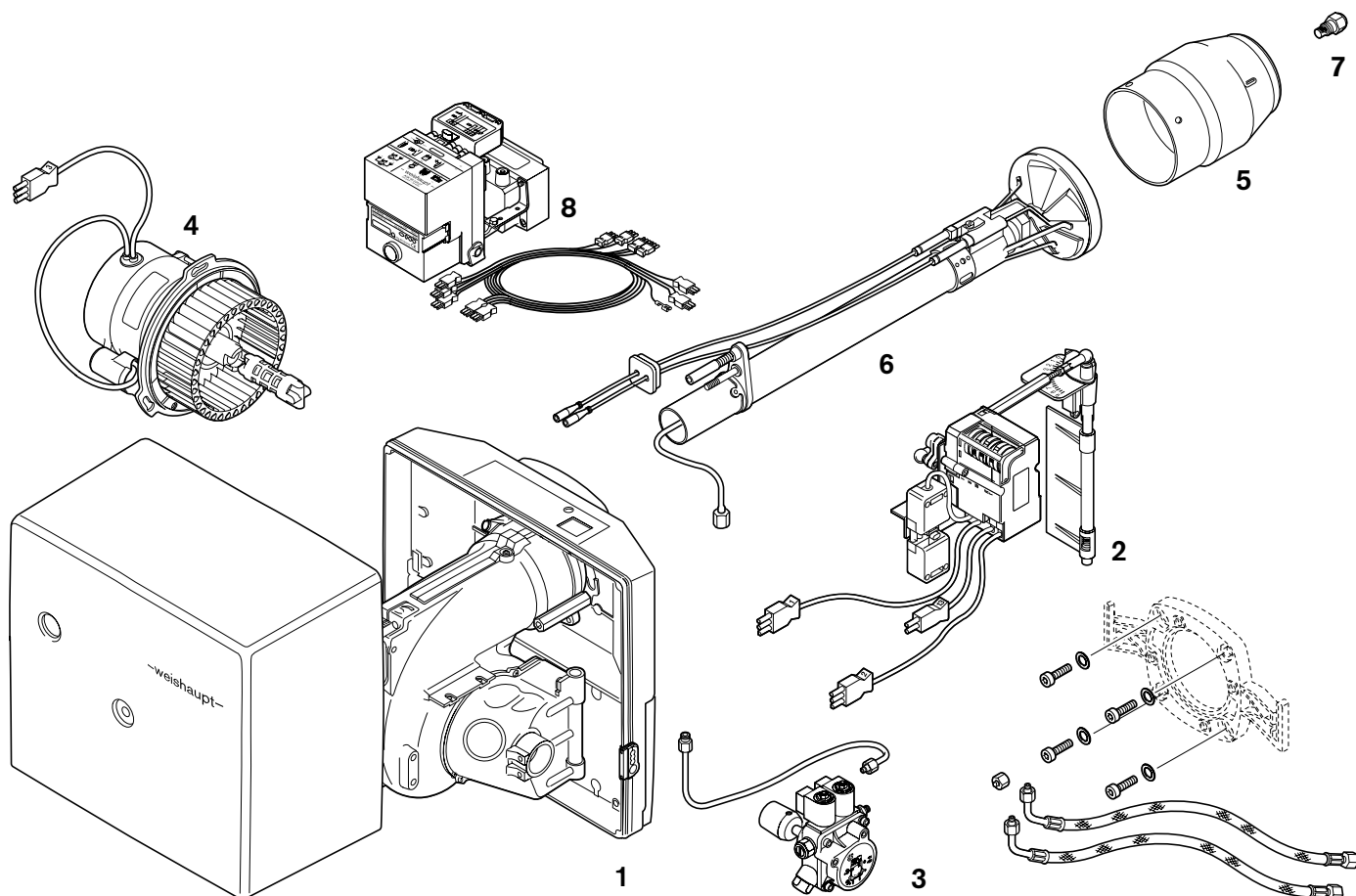

Ersatzteile nach Baugruppen geordnet:

- 1. Brennergehäuse
- 2. Luftregler
- 3. Pumpe
- 4. Gebläse mit Motor
- 5. Flammkopf
- 6. Düsenstock
- 7. Düsen
- 8. Flammenüberwachung/Zündtrafo

← Zurück / Back / Retour



Bild Pict. Photo	Bezeichnung Brenner-Typenreihe Burner serie Type brûleur	Bestell-Nr. Order-No. No de commande	ca. kg appr. kg env. kg	Designation	Désignation		
1.	Brennergehäuse			Burner casing	Carcasse Brûleur		
1.1	Brennergehäuse			Spiral casing	Volute		
1.2	WL20-A	241 200 0101/2	E	1,853			
1.3	WL20Z	241 203 0101/2	E	1,919			
	WL20Z-LN	241 203 0102/2	E	1,919			
1.4	Stirnplatte	WL20(Z)	241 200 0106/7	E	1,300	Front plate	
1.5	WL20 - WTU	241 200 0126/7	E	0,870			
1.6	Ansauggehäuse	WL20(Z)	241 200 0107/7	E	0,440	Air intake	
1.7	Auskleidung	WL20/1./2(Z)	241 200 0108/7	E	0,098	Lining	
1.8	WL20/3(Z)	241 200 0115/7	E	0,089			
1.9	Brennerflansch	WL20(Z)	241 200 0110/2	E	0,860	Burner flange	
1.10	WL20 - WTU	241 200 0111/2	E	0,596			
1.11	Sechskantmutter				Hexagon nut		
	M8 x 75	WL20-A	241 100 0112/7	E	0,074	Ecrou hexagonal	
1.12	Schraube	M8 x 30 DIN 84	402 502	E	0,002	Screw	
						Vis	
1.13	Flanschdichtung				Flange sealing	Joint	
	160 x 115	WL20(Z)	241 200 0114/7	E	0,098		
1.14	Flammrohrhalter	WL20(Z)	241 200 0127/7	E	0,265	Holder for flame tube	
1.15	WL20 - WTU	241 200 0128/7	E	0,265			
1.16	Abdeckhaube	WL20(Z)	241 200 0103/2	E	1,250	Cover	
1.17	Stahlblech, lackiert	WL20(Z)	240 200 0104/2	E	2,909	Steel, painted	
1.18	Edelstahl	WL20(Z)	240 200 0105/2	E	2,908	Refined steel	
1.19	Schraube	M8 x 15	142 013 0115/7	E	0,002	Screw	
						Vis	
1.20	Scheibe	7 x 18 x 0,6	430 016	Z	0,001	Washer	
						Rondelle	
1.21	Schauglas		241 200 0117/7	E	0,003	Sight glass	
						Verre de protection	
1.22	Tülle - Anschlußkabel		241 200 0124/7	E	0,010	Transition nipple	
1.23	- Luftregelgehäuse		241 200 0119/7	E	0,007		
						Joint couchoouc	
1.24	Stauring	WL20-A(Z)	241 200 0122/7	E	0,047	Air distributor disc	
						Diffuseur d'air	
1.25	Einsteckfassung, grün		725 333	E	0,001	Lamp holder	
						Support de lampe	
1.26	Halteblech	2 x 10 x 46	WL20	241 300 0126/7	E	0,010	Bracket
						Tôle support	
1.27	Schraube	12 x 10 x 38 x M 6	241 200 1005/7	E	0,002	Screw	
						Vis	
1.28	O-Ring	8,5 x 2	445 105	Z	0,001	O-ring	
						Joint O	
1.29	Zubehör-Garnitur	WL20(Z)	241 200 0001/2	E	0,077	Attachment accessories	
						Boulons de fixation	
	Ölschlauch					Flexible fioul	
	Für Heizöl bis max. 70°C					Pour FOD	
						max. 70°C	
						Longueur mm Raccord	
1.30	Länge mm	Anschluß					
	DN 4	G 3/8"	WL20(Z)	491 125	E	0,280	
1.31	Kabelschelle	WTU	241 100 0002/7	E	0,003	Cable clamp	
						Gaine de câble	
1.32	Stopfen	WTU	452 864	Z	0,001	Plug	
						Bouchon	
1.33	Stehbolzen	WTU	241 100 0005/7	E	0,093	Stay bolt	
						Entretoise	
1.34	Verschlußbutzen mit Mutter		241 100 0601/2	E	0,020	Closing piece	
						Buchon	
1.35	Schraube	M8 x 25	402 500	E	0,002	Screw	
						Vis	
1.36	Scheibe	8,4 DIN 433	430 504	Z	0,001	Washer	
						Rondelle	



Bild Pict. Photo	Bezeichnung Brenner-Typenreihe Burner serie Type brûleur		Bestell-Nr. Order-No. No de commande		ca. kg appr. kg env. kg	Designation	Désignation
2.	Luftregler					Air regulator	Régulateur d'air
2.1	Luftklappe	WL20(Z)	241 200 0201/2	E	0,034	Air flap	Clapet d'ai
2.2	Kugelzapfen A8/M5	WL20Z-B	499 179	E	0,002	Ball end	Rotule
2.3	Platte	WL20Z-B	241 203 0201/7	E	0,031	Plate	Plaque
2.4	Welle 7 x 71,5	WL20Z-B	241 203 0203/7	E	0,018	Shaft	Boudron
2.5	Sechskantmutter M 5	WL20-A	411 203	E	0,074	Hexagon nut	Ecrou hexagonal
2.7	Grundplatte	WL20Z-B	241 203 0201/2	E	0,043	Ground plate	Plaque
2.8	Stellantrieb W-ST01/4 110V, 60 Hz 220-230V, 50 Hz 220-230V, 60 Hz	WL20-A	651 027 651 026 651 038	E E E	0,265 0,268 0,268	Servo motor	Servo moteur
2.9	Stellantrieb STA 4,5 mit Steckerkabel	WL20Z-B	241 303 1518/2	E	0,442	Servo motor STA 4,5 with plug cable	Servo moteur STA 4,5 avec câble
2.10	Stellantrieb STA 4,5 ohne Steckerkabel	WL20Z-B	651 043	E	0,304	Servo motor STA 4,5 without plug cable	Servo moteur STA 4,5 sans câble
2.11	Steckerteil 18/4 mit aufgeschraubter Kappe	WL20Z-B	716 087	E	0,031	Plug part	Fiche
2.12	Befestigungsbügel	WL20Z-B	241 203 1514/7	E	0,250	Bracket	Etrier
2.13	Hebel für Stellantrieb	WL20Z-B	241 203 1513/7	E	0,050	Lever	Levier
2.14	Regelgestänge Luftregler	WL20Z-B	241 203 1517/2	E	0,045	Regulating rod Air regulator	Tige de réglage Régulateur d'air
2.15	Hebel	WL20Z-A-H	241 203 1502/7	E	0,050	Lever	Levier

3.4
-3.5

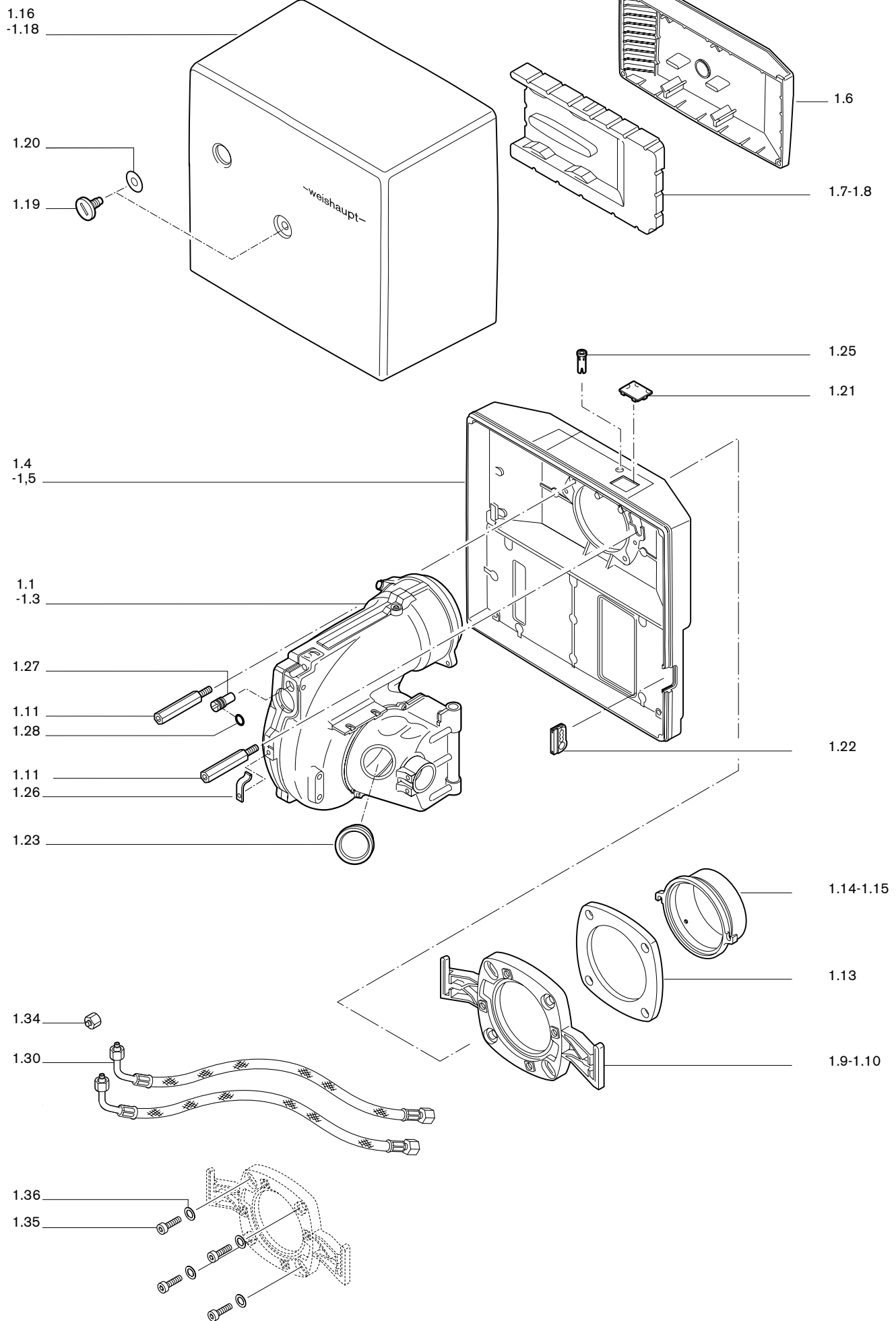

3.3

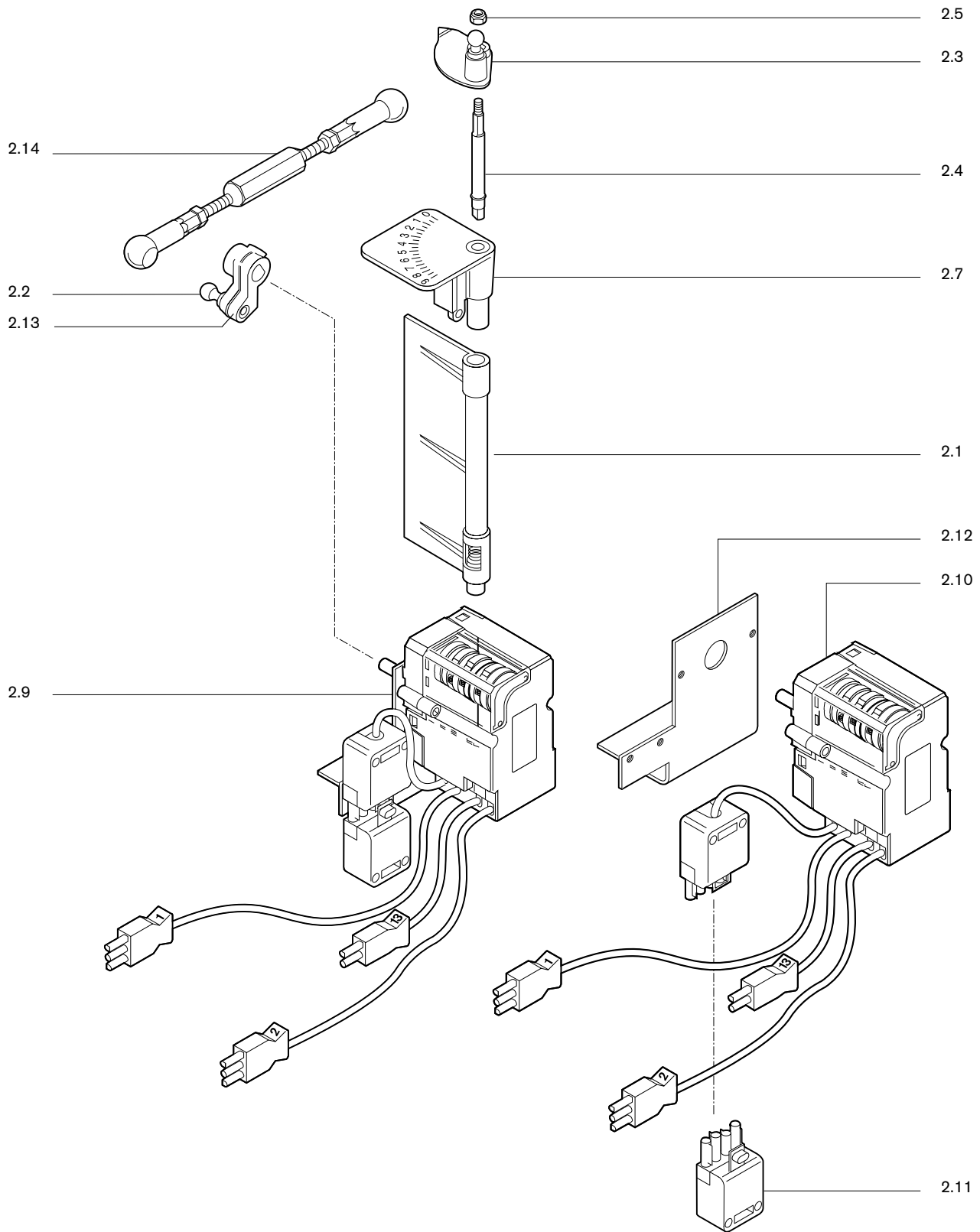
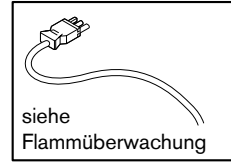
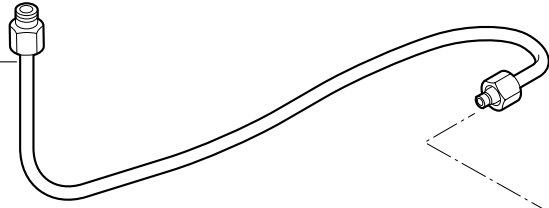
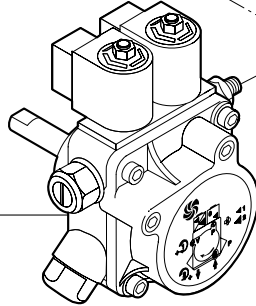

3.1
-3.2

4.1

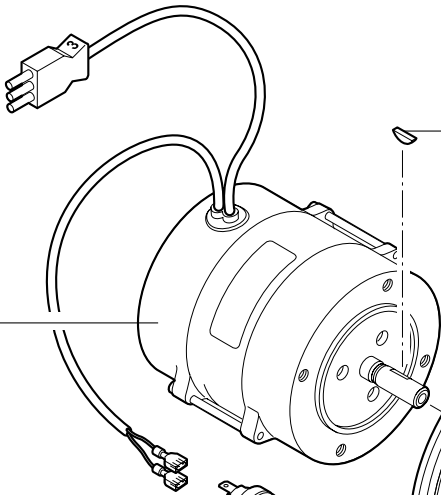

4.3

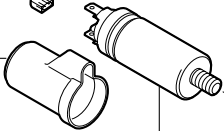

4.2

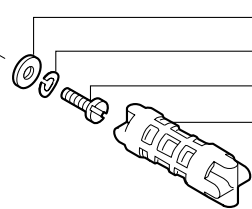
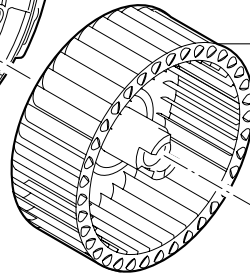
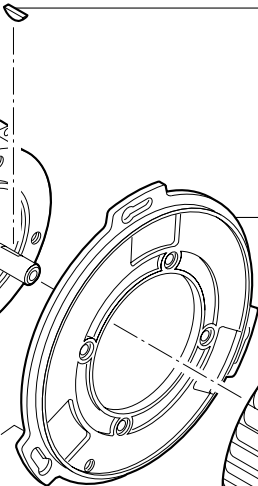

4.4

4.5

4.6

4.7

4.9

4.8

4.10

5.1



Bild Pict. Photo	Bezeichnung Brenner-Typenreihe Burner serie Type brûleur	Bestell-Nr. Order-No. No de commande			ca. kg appr. kg env. kg	Designation	Désignation
3.	Pumpe					Pump	Pompe
	Pumpen , Weishaupt funktions- und dichtsgeprüft					Pumps , Weishaupt factory tested	Pompes testées à l'usine Weishaupt
3.1	Pumpentyp AL 30 C 9537 WL20-A AL 30 C 9518 WL20-A-H-(U)	601 212 601 214	E E		1,183 1,177	Pump type	Pompe type
3.2	AT 2 45 C 9563-2P 0500 R WL20Z u. LN	601 196	E		1,315		
3.3	Pumpenkupplung WL20(Z)	142 013 0901/2	E		0,042	Pump coupling	Accouplement de pompe
3.4	Ölleitung Pumpe-Verschraubung WL20(Z)	241 200 0605/2	E		0,027	Oil line Pump-Screwing	Canalisation fioul Pompe-Raccord
3.5	Verschraubung-Pumpe WL20 -H	242 200 0602/2	E		0,035	Screwing-Pump	Raccord-Pompe
3.6	Pumpen-Anschlußteile WL20(Z)	240 100 0601/2	E		0,044	Pump connection parts	Pièces de raccordement
3.7	Filtersatz AL 30	601 106	E		0,015	Filter set	Filtere
3.8	Magnetventilsule , 50-60 Hz					Solenoid valve	Bobine de vanne
3.9	für AL 30/AT 2 45 100-127 V 185-254 V	604 428 604 429	E E		0,062 0,064		
3.10	Schlauchschelle WTU	241 100 0001/7	E		0,006	Hose clamp	Gaine flexible
4.	Gebläse mit Motor					Blower with motor	Ventilation avec moteur
	Bei Bestellung Spannung und Frequenz angeben.					When ordering indicate voltage and frequency	A la commande indiquer la tension et la fréquence
4.1	Brennermotor , 50 Hz mit Befestigungsschrauben Typ V Upm ECK 04-2 230 2800 WL20(Z)	241 200 0714/0	E		3,233	Burner motor	Moteur de brûleur
4.2	Kondensator 5 µF, zu Motor ECK 04-2 WL20(Z)	713 124	E		0,051	Capacitor to motor	Condensateur pour moteur
4.3	Schutzkappe für Kondensator DN 30 x 41 für ECK 04-2 WL20(Z)	241 100 0703/7	E		0,004	Protective sleeve for capacitor	Capuchon de protection pour condensateur
4.4	Scheibenfeder 3 x 3,7	490 157	Z		0,001	Woodruff key	Clavette disque
4.5	Motorzwischenflansch WL20(Z)	241 200 0112/7	E		0,171	Intermediate motor flange	Bride intermédiaire moteur
4.6	Gebläserad 133 x 50, verzinkt, 50 Hz WL20(Z)	241 200 0802/2	E		0,325	Blower	Turbine
4.7	Unterlegscheibe f. Gebläseradbefestigung	141 111 0802/7	E		0,002	Washer for blower wheel attachment	Rondelle plate pour fixation turbine
4.8	Schraube M 4 x 12	402 112	Z		0,002	Screw	Vis
4.9	Federring B4	435 100	Z		0,001	Spring ring	Rondelle ressort
4.10	Kupplungsmittelstück WL20(Z)	241 200 0901/7	E		0,024	Intermediate piece	Pièce intermédiaire
5.	Flammkopf					Combustion head	Tête de combustion
5.1	Flammrohr W 20/1 W20/2 W20/3 W20/1LN W20/2LN W20/3LN	241 200 1401/7 241 200 1403/7 241 200 1411/7 241 200 1445/2 241 200 1454/2 241 200 1455/2	E E E E E E		0,384 0,384 0,416 0,400 0,400 0,425	Flame tube	Tube de combustion
	Flammkopfverlängerung (ohne Bild)					Combustion head extension (without picture)	Rallonge de tête de combustion (sans photo)
5.2	Brenner Verlängerung mm WL 20/1 100 WL 20/2 WL 20/3	240 200 1401/0 240 200 1402/0 240 200 1403/0	E E E		1,210 1,210 1,441		
5.3	WL 20/1 200 WL 20/2 WL 20/3	240 200 1404/0 240 200 1405/0 240 200 1406/0	E E E		1,650 1,650 1,820		
5.4	WL 20/1 300 WL 20/2 WL 20/3	240 200 1407/0 240 200 1408/0 240 200 1409/0	E E E		1,800 2,157 2,303		
5.5	Flammkopfaufsatz W20/1LN W20/2LN	241 200 1450/2 241 200 1451/2	E E		0,327 0,334	Combustion head addition	



Bild Pict. Photo	Bezeichnung Brenner-Typenreihe Burner serie Type brûleur	Bestell-Nr. Order-No. No de commande		ca. kg appr. kg env. kg	Designation	Désignation	
6.	Düsenstock				Nozzle assembly	Ligne de gicleur	
6.1	Düsenstock ohne Vorwärmung				Nozzle assembly without preheating device	Corps de gicleur sans chauffage	
	WL20/1	241 200 1001/0	E	0,584			
	WL20/2	241 200 1002/0	E	0,584			
	WL20/3	241 200 1003/0	E	0,620			
	WL20Z/1	241 203 1001/0	E	0,200			
	WL20Z/3LN	241 203 1004/0	E	0,655			
6.2	Düsenstock mit Vorwärmung				with preheating device	avec chauffage	
	WL20/1-H	242 200 1001/0	E	0,436			
	WL20/2-H	242 200 1002/0	E	0,817			
	WL20/3-H	242 200 1003/0	E	0,845			
	WL20/1LN	242 200 1004/0	E	0,900			
	WL20/2LN	242 200 1005/0	E	0,900			
	WL20Z/1-H	242 203 1001/0	E	0,280			
	WL20Z/3LN	242 203 1004/0	E	0,350			
6.3	Düsenkopf ohne Vorwärmung				Nozzle head without preheating device	Ligne de gicleur sans chauffage	
	WL20-A	241 200 1005/2	E	0,193			
	WL20/3LN	241 200 1016/2	E	0,193			
6.4	Düsenkopf mit Vorwärmung	WL20-H(Z)	242 200 1006/2	E	0,433	with preheating device	avec chauffage
6.5	Gewindebolzen	M6 x 50	142 013 0219/7	E	0,010	Threaded bolt	Goujon fileté
6.6	Führungsrohr	WL20-A	241 200 1010/2	E	0,242	Guide tube	Douille
6.7	Zündkabel mit Tülle und Dämpfungswiderstand 350 mm		240 200 1121/2	E	0,018	Ignition line	Câble d'allumage
6.8	Tülle für Zündkabel		241 200 0116/7	E	0,005	Bushing	Bouchon
6.9	Spannfeder		142 013 1024/7	E	0,002	Tension spring	Étrier de fixation
6.10	Zündelektrode	WL20/1-2 WL20-3 WL20LN	241 200 1018/7 241 200 1020/7 241 200 1452/7	E E E	0,018 0,020 0,023	Ignition electrode	Électrode d'allumage
6.11	Stauscheibe	W20/1 WL20-A(Z) W20/2 WL20-A(Z) W20/3 WL20-A(Z)	241 200 1420/2 241 200 1421/2 241 200 1422/2	E E E	0,066 0,079 0,113	Air diffuser disk	Défecteur
		W20/1LN W20/2LN W20/3LN	241 200 1446/2 241 200 1452/2 241 200 1453/2	E E E	0,148 0,160 0,189		
6.12	Wärmetauscher		242 100 1007/2	E	0,088	Heat exchanger	Échangeur de chaleur
6.13	Temperaturschalter, 45° mit Anschlusskabel		242 100 1008/2	E	0,027	Temperature switch	Thermostat
6.14	Düsenkörper für Vorwärmung	WL20-A	242 200 1005/2	E	0,235	Nozzle body	Corps de gicleur
6.15	Düsenabschluss-Set	WL20	240 100 1005/2	E	0,039	Nozzle shut off set	
6.16		WL20/LN	240 100 1004/2	E	0,039		
6.17	O-Ring 12 x 2		445 029	Z	0,001	O-ring	Joint torique
6.18	Zündelektrodenhalter	WL20/1LN WL20/2 - /3LN	241 200 1448/2 241 200 1456/2	E E		Ignition electrode support	Support électrode

7.1-
7.12

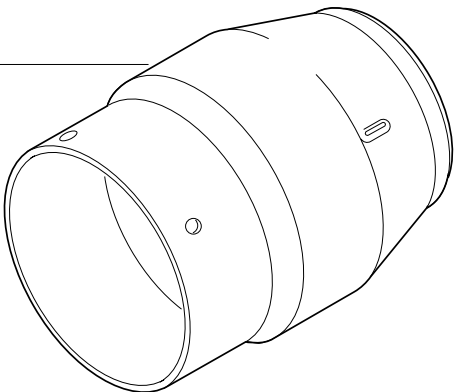

Bild Pict. Photo	Bezeichnung Brenner-Typenreihe Burner serie Type brûleur	Bestell-Nr. Order-No. No de commande		ca. kg appr. kg env. kg	Designation	Désignation
7.	Düsen				Nozzles	Gicleurs
7.1	Düsen Fabrikat Monarch Größe in US Gph bei 8 bar Typ R - 45° Vollstrahl				Monarch manufacture Size in US gph at 8 bar Solid spray	Fabrication Monarch grandeur en US Gph à 8 bar Cône-plein
	0,50	602 293	E	0,028		
	0,60	602 294	E	0,028		
	0,65	602 295	E	0,027		
	0,75	602 296	E	0,028		
	0,85	602 297	E	0,029		
	1,00	602 298	E	0,029		
	1,10	602 316	E	0,027		
	1,20	602 305	E	0,027		
	1,25	602 317	E	0,027		
	1,35	602 306	E	0,027		
	1,50	602 307	E	0,027		
	1,65	602 308	E	0,027		
	1,75	602 309	E	0,027		
	2,00	602 310	E	0,027		
	2,25	602 311	E	0,027		
	2,50	602 312	E	0,027		
	3,00	602 313	E	0,027		
	3,50	602 314	E	0,027		
7.2	Düsen Fabrikat Monarch Größe in US Gph bei 8 bar Typ R - 60° Vollstrahl				Monarch manufacture Size in US gph at 8 bar Solid spray	Fabrication Monarch grandeur en US Gph à 8 bar Cône-plein
	0,50	602 343	E	0,028		
	0,60	602 344	E	0,028		
	0,65	602 345	E	0,028		
	0,75	602 346	E	0,028		
	0,85	602 347	E	0,028		
	1,00	602 348	E	0,029		
	1,10	602 355	E	0,027		
	1,20	602 356	E	0,027		
	1,25	602 357	E	0,027		
	1,35	602 358	E	0,027		
	1,50	602 359	E	0,027		
	1,65	602 360	E	0,027		
	1,75	602 361	E	0,027		
	2,00	602 362	E	0,027		
	2,25	602 363	E	0,027		
	2,50	602 364	E	0,027		
	3,00	602 365	E	0,027		
	3,50	602 366	E	0,027		
7.3	Düsen Fabrikat Steinen Größe in US Gph bei 8 bar Typ S - 45° Vollstrahl				Steinen manufacture Size in US Gph at 8 bar Solid spray	Fabrication Steinen grandeur en US Gph à 8 bar Cône plein
	0,40	612 003	E	0,028		
	0,45	612 005	E	0,028		
	0,50	612 001	E	0,025		
	0,55	612 007	E	0,028		
	0,60	612 002	E	0,025		
	0,65	612 051	E	0,025		
	0,75	612 004	E	0,025		
	0,85	612 006	E	0,025		
	1,00	612 008	E	0,025		
	1,10	612 009	E	0,025		
	1,25	612 011	E	0,025		
	1,35	612 012	E	0,025		
	1,50	612 013	E	0,025		
7.4	Düsen Fabrikat Steinen Größe in US Gph bei 8 bar Typ S - 60° Vollstrahl				Steinen manufacture Size in US Gph at 8 bar Solid spray	Fabrication Steinen grandeur en US Gph à 8 bar Cône plein
	0,40	612 198	E	0,027		
	0,45	612 199	E	0,028		
	0,50	612 200	E	0,025		
	0,55	612 202	E	0,028		
	0,60	612 201	E	0,025		
	0,65	612 250	E	0,025		
	0,75	612 203	E	0,025		
	0,85	612 206	E	0,027		
	1,00	612 207	E	0,025		
	1,10	612 208	E	0,025		
7.4	Düsen Fabrikat Steinen Größe in US Gph bei 8 bar Typ S - 60° Vollstrahl				Fluidics manufacture Size in US Gph at 8 bar Solid spray	Fabrication Fluidics grandeur en US Gph à 8 bar Cône plein
	1,25	612 210	E	0,025		
	1,35	612 211	E	0,025		
	1,50	612 212	E	0,025		
	1,65	612 213	E	0,025		
	1,75	612 214	E	0,025		
	2,00	612 216	E	0,025		
	2,25	612 217	E	0,025		
	2,50	612 251	E	0,025		
	2,75	612 218	E	0,025		
	3,00	612 219	E	0,025		
	3,50	612 220	E	0,025		

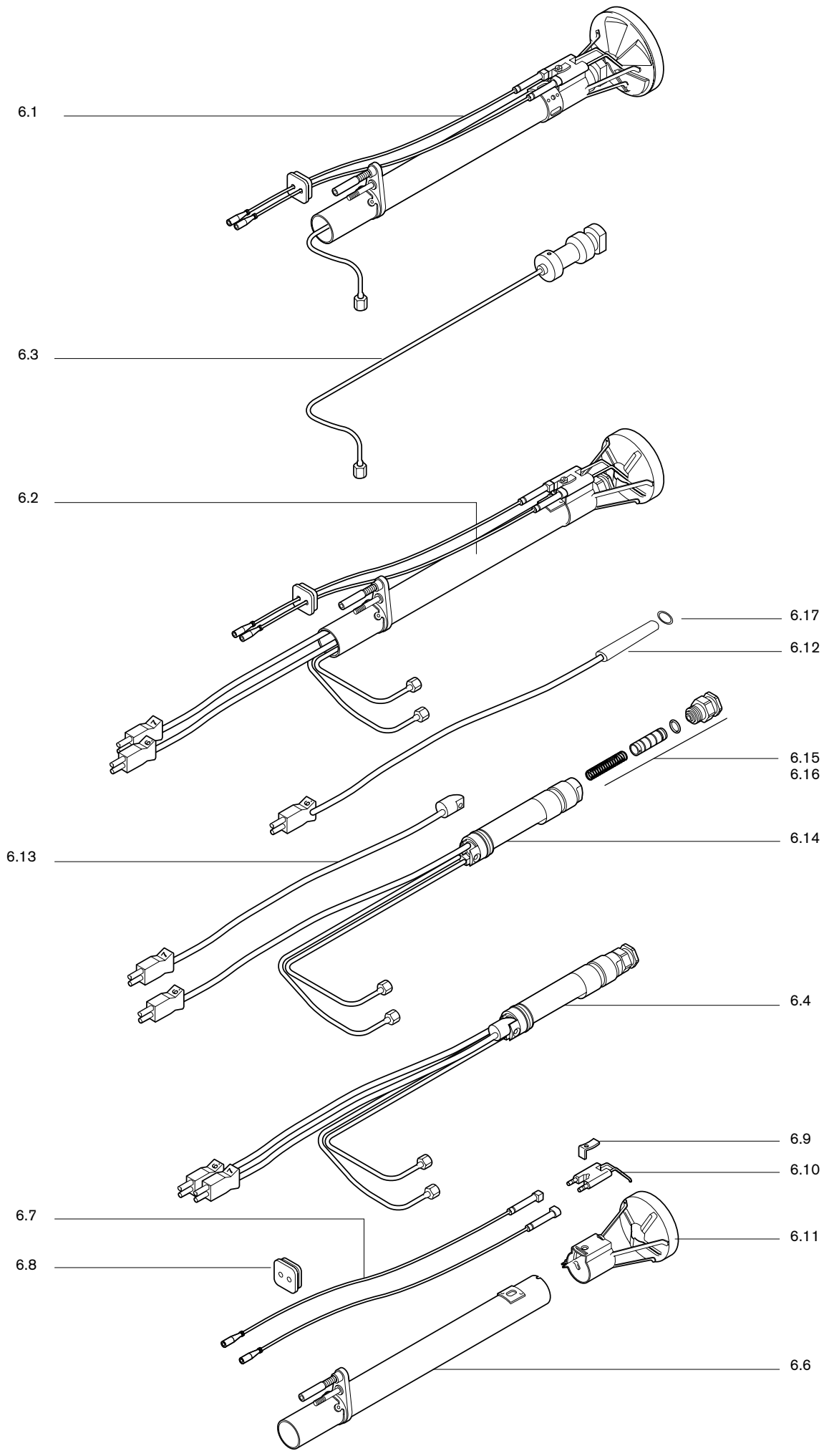
7.1-
7.12



Bild Pict. Photo	Bezeichnung Brenner-Typenreihe Burner serie Type brûleur	Bestell-Nr. Order-No. No de commande		ca. kg appr. kg env. kg	Designation	Désignation	
7.5	Düsen Fabrikat Steinen Größe in US Gph bei 8 bar Typ H - 60° Hohlstrahl				Fluidics manufacture Size in US Gph at 8 bar Hollow spray	Fabrication Fluidics grandeur en US Gph à 8 bar Cône creux	
		0,45	612 510	E	0,027		
		0,55	612 511	E	0,027		
		0,65	612 512	E	0,027		
		0,75	612 513	E	0,027		
		0,85	612 514	E	0,027		
		1,00	612 517	E	0,027		
		1,10	612 518	E	0,027		
		1,25	612 519	E	0,027		
		1,35	612 520	E	0,027		
		1,50	612 521	E	0,027		
		1,65	612 522	E	0,027		
		1,75	612 515	E	0,027		
		2,00	612 516	E	0,027		
		2,25	612 523	E	0,027		
7.6	Typ PH - 60° Hohlstrahl	2,50	612 524	E	0,027		
		2,75	612 525	E	0,027		
		3,00	612 526	E	0,027		
7.7	Düsen Fabrikat Steinen Größe in US Gph bei 8 bar Typ H - 80° Hohlstrahl				Fluidics manufacture Size in US Gph at 8 bar Hollow spray	Fabrication Fluidics grandeur en US Gph à 8 bar, Cône creux	
		0,60	612 420	E	0,027		
		0,65	612 421	E	0,027		
		0,75	612 422	E	0,027		
		0,85	612 423	E	0,027		
1,00	612 424	E	0,027				
7.8	Düsen Fabrikat Fluidics Größe in US Gph bei 8 bar Typ SF - 45° Vollstrahl				Fluidics manufacture Size in US Gph at 8 bar Solid spray	Fabrication Fluidics grandeur en US Gph à 8 bar Cône plein	
		0,40	602 701	E	0,030		
		0,45	602 702	E	0,030		
		0,50	602 703	E	0,030		
		0,55	602 704	E	0,031		
		0,60	602 705	E	0,031		
		0,65	602 706	E	0,030		
7.9	Düsen Fabrikat Fluidics Größe in US Gph bei 8 bar Typ HF - 45° Hohlstrahl				Fluidics manufacture Size in US Gph at 8 bar Hollow spray	Fabrication Fluidics grandeur en US Gph à 8 bar Cône creux	
		0,40	602 677	E	0,030		
		0,45	602 678	E	0,030		
		0,50	602 679	E	0,030		
		0,55	602 680	E	0,030		
		0,60	602 681	E	0,030		
		0,65	602 682	E	0,030		
		0,75	602 683	E	0,030		
		0,85	602 684	E	0,030		
		1,00	602 710	E	0,030	Hollow spray	Cône creux
		1,10	602 711	E	0,030		
		1,20	602 712	E	0,030		
		1,25	602 713	E	0,030		
		1,35	602 714	E	0,030		
		1,50	602 715	E	0,030		
1,65	602 716	E	0,030				
1,75	602 717	E	0,030				
2,00	602 718	E	0,030				
2,25	602 719	E	0,030				
7.10	Düsen Fabrikat Fluidics Größe in US Gph bei 8 bar Typ SF - 60° Vollstrahl				Fluidics manufacture Size in US Gph at 8 bar Solid spray	Fabrication Fluidics grandeur en US Gph à 8 bar Cône plein	
		0,40	602 741	E	0,031		
		0,45	602 742	E	0,033		
		0,50	602 743	E	0,031		
		0,55	602 744	E	0,030		
		0,60	602 745	E	0,030		
0,65	602 746	E	0,031				
7.11	Düsen Fabrikat Fluidics Größe in US Gph bei 8 bar Typ H- 45° Hohlstrahl				Fluidics manufacture Size in US Gph at 8 bar Hollow spray	Fabrication Fluidics grandeur en US Gph à 8 bar	
		2,50	602 685	E	0,031		
		2,75	602 686	E	0,031		
		3,00	602 687	E	0,031		
3,50	602 688	E	0,031				
7.12	Düsen Fabrikat Fluidics Größe in US Gph bei 8 bar Typ HF- 60° Hohlstrahl				Fluidics manufacture Size in US Gph at 8 bar Hollow spray	Fabrication Fluidics grandeur en US Gph à 8 bar Cône creux	
		0,40	602 725	E	0,031		
		0,45	602 720	E	0,033		
		0,50	602 726	E	0,031		
		0,55	602 721	E	0,030		
		0,60	602 727	E	0,030		
		0,65	602 722	E	0,031		
		0,75	602 723	E	0,031		
		0,85	602 724	E	0,033		
		1,00	602 728	E	0,030		
		1,10	602 729	E	0,030		
		1,25	602 730	E	0,027		
		1,35	602 731	E	0,027		
		1,50	602 732	E	0,027		
		1,65	602 733	E	0,027		
1,75	602 734	E	0,027				
2,00	602 735	E	0,027				
2,25	602 736	E	0,027				
2,50	602 737	E	0,027				
2,75	602 738	E	0,027				
3,00	602 739	E	0,027				
3,50	602 760	E	0,027				

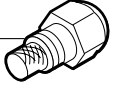
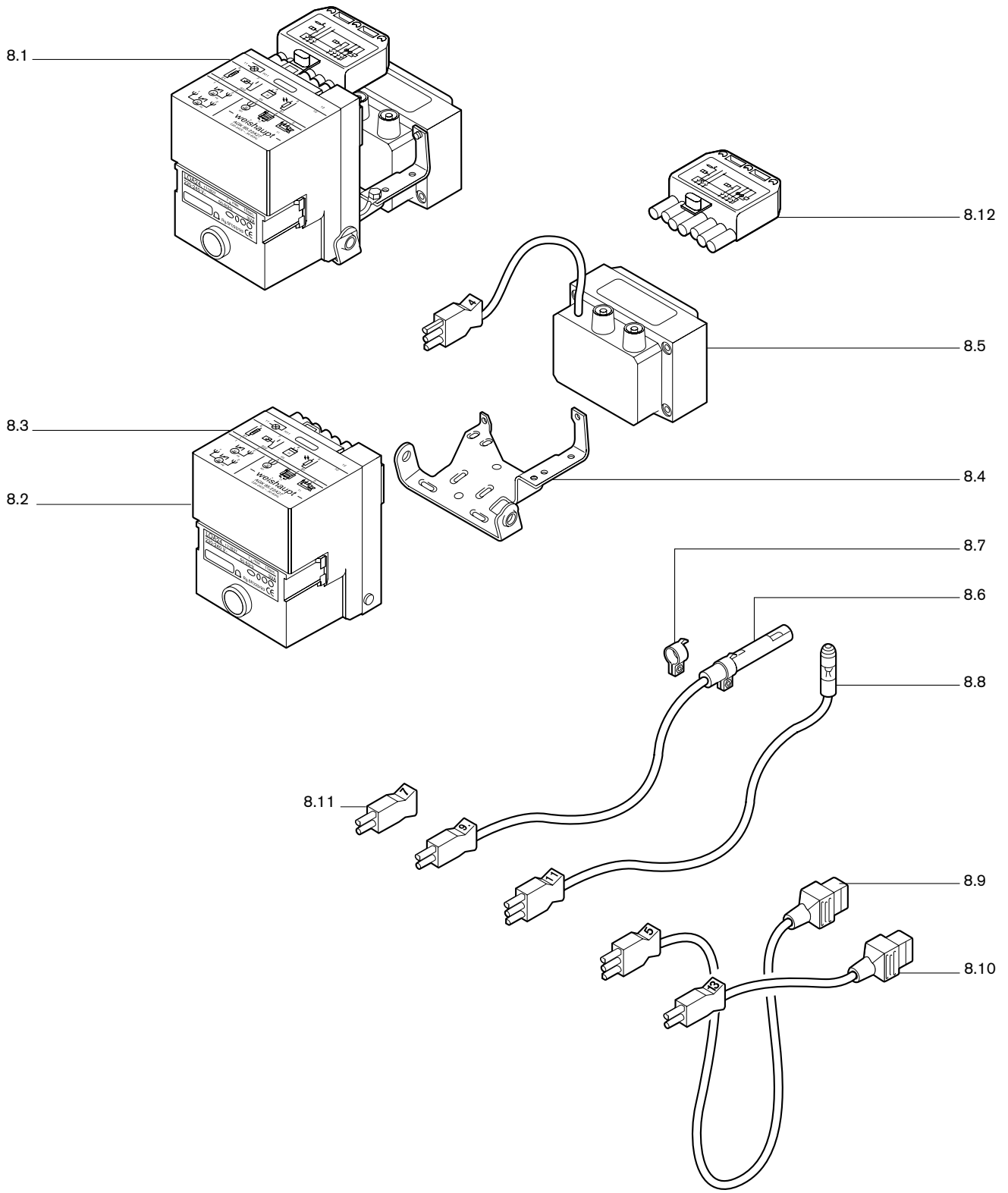

Bild Pict. Photo	Bezeichnung Brenner-Typenreihe Burner serie Type brûleur	Bestell-Nr. Order-No. No de commande		ca. kg appr. kg env. kg	Designation	Désignation
8.	Flammenüberwachung/Zündtrafo				Burner control/ Ignition trafo	Coffret de sécurité/ Transformateur d'allumage
	Preise für Sonderspannungen auf Anfrage				Price for special voltage on inquiry	Prix pour tension spéciale sur demande
8.1	Konsole mit Zündtrafo , 230V, 50-60 Hz sek. 2x3750 V	241 150 1202/2	E	1,322	Ignition transformer	Transformateur
8.2	Feuerungsautomat , 220-240V, 50-60 Hz LOA 24.171 LOA 26.171 WTU	600 206 600 216	E E	0,180 0,188	Burner control	Coffret
8.3	Anschlußkonsole AGK 85.22 AGK 85.30 WTU	600 531 600 536	E E	0,246 0,262	Terminal socket	Socle
8.4	Befestigungsbügel f. Anschlußkonsole	142 013 1211/7	E	0,023	Attachment bracket	Etrier
8.5	Zündtrafo ZA 23075 E 37 , 220-240 V, 50-60Hz	603 088	E		Ignition transformer	Transformateur d'allumage
8.6	Flammenfühler QRB1 B WL20(Z) QRB1 C WL20LN	142 013 1214/2 241 200 1209/2	E E	0,023 0,024	Flame sensor	Cellule
8.7	Bride für QRB	600 566	E	0,002	Flange	Bride
8.8	Signalleuchte (Nr. 11) 3-polig 230V, 50-60 Hz,	241 200 1205/2	E	0,018	Operating lamp	Voyant de marche
8.9	Steckerkabel (Nr. 5) 3-polig	142 013 1215/2	E	0,025	Connection cable	Câble de raccordement
8.10	(Nr. 13) 2-polig	241 203 1512/2	E	0,030		
8.11	Zwischenstecker (Nr. 7) 2-polig (ohne Temperatur-Regler)	241 200 1202/2	E	0,009	Plug	Prise intermédiaire
8.12	Steckverbindung Steckerteil ST 18/7	716 089	E	0,035	Plug connection Plug part	Connecteur Fiche
8.13	Zeitzähler (einstufig) mit Kabel Nr. 8	240 100 8505/2	E	0,050	Time counter	Compteur horaire
8.14	Zeitzähler (zweistufig) mit Kabel Nr. 8	240 203 8506/2	E	0,099	Time counter	Compteur horaire
8.15	Ölzähler Aqua-Metro, 50 l/h, G1/8"	606 044	Z	0,685	Oil counter	Compteur fuel
8.16	Anschlußstecker ST 18/7 WTU	130 101 1219/2	E	0,248	Plug	Bouchon